



Range of double inlet direct driven low pressure centrifugal fans manufactured from galvanised sheet steel. All the models are fitted with forward curved centrifugal impellers manufactured from galvanised sheet steel.

Motors

Housing closed motors, IP44, class F, equipped with thermal protection and ball bearings greased for life.

Electrical supply:

4 or 6 pole depending on version.

Single phase 230V-50Hz (capacitor fitted on the fan housing).

Three phase 230/400V-50Hz.

(See characteristics chart).

On request

Housing open motors IP20, class F.

Coupling flange fitted at the fan outlet (B version).

Special version kitchen IP55, class F.

Three phase motors suitable for frequency inverter control.



Anti-vibration mounts

All motors are fitted with support including rubber antivibration mounts reducing the noise transmitted to the installation.



Impeller dynamically balanced

Impeller dynamically balanced, according to ISO 1940 standard, providing vibration free operation.

POSITIONS

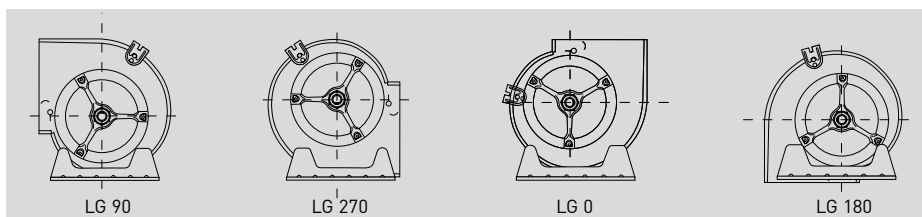

Mounting feet (accessory) allow 4 positions of the inlet discharge.

REFERENCE

CBM	9/9	373	6P	T	C	VR	K	B8	MP	IP55
1	2	3	4	5	6	7	8	9	10	11

- 1 - Product range.
- 2 - 7/7, 9/7, 9/9, 10/8, 10/10, 12/9, 12/12, 15/15
Wheel dimensions in inches.
- 3 - Motor Power (W).
- 4 - 4P, 6P: Number of pole.
- 5 - Nothing: Single phase.
T: Three phase.
- 6 - C: Closed motor (IP44).
RE: External Rotor Motor.
Nothing: Open motor (IP20).
- 7 - Nothing: 1 speed - motor.
2V: fan with 2 speed motor.
3V: fan with 3 speed motor.
VR: Speed controllable motor by tension.
EC-0-10V, EC-CK, EC-PK, EC-CK/DG:
motor with electronic control.
- 8 - Nothing: Standard CBM.
K: CBM Reinforced cubic structure.
- 9 - Nothing: Standard CBM.
B10, B11, B5, B7, B8, B9, BE: CBM fitted
with outlet coupling flange.
The number indicates the fixing holes
diameter.
- 10 - Nothing: Product on individual packing.
MP: Multi product palletizing.
- 11 - IP rating.

TECHNICAL CHARACTERISTICS

Before installation check that the product electrical characteristics listed on the data plate label (voltage, power, frequency, etc.) match those of the intended electrical supply.

Model	Speed poles	Motor power (W)	Capacitor (µF/V)	Maximum absorbed current (A)	Airflow (m³/h)	Maximum temperature (°C)	Sound pressure level* (dB(A))	Weight (kg)	Speed controller	
									REB	RMB

SINGLE PHASE

CBM-7/7 72 6P C VR	6	72	3/450	0,6	1080	50	51	6,7	1	1,5
CBM-9/7 373 4P C VR	4	373	10/450	3,8	2560	40	68	11,3	5	8
CBM-9/9 373 4P C VR	4	373	10/450	3,9	2810	40	66	12,4	5	8
CBM-9/9 550 4P C	4	550	15/450	4,5	3440	40	70	14	-	-
CBM-10/8 245 6P C VR	6	245	10/450	2,3	2730	40	62	13	5	3,5
CBM-10/8 373 4P C	4	373	25/450	4,5	3310	40	68	15	-	-
CBM-10/10 245 6P C VR	6	245	10/450	2,4	3220	40	62	14,6	5	3,5
CBM-10/10 550 4P C VR	4	550	25/450	4,5	3390	40	66	15,3	5	8
CBM-12/9 550 6P C VR	6	550	18/450	5,5	4610	40	66	22	10	8
CBM-12/9 736 6P C	6	736	20/450	7,6	5750	40	70	24,2	-	-
CBM-12/12 736 6P C	6	736	20/450	8,2	5960	40	70	26,5	-	-

Model	Speed poles	Motor power (W)	Maximum absorbed current		Airflow (m³/h)	Maximum temperature (°C)	Sound pressure level* (dB(A))	Weight (kg)	Variable frequency inverter VTFM Electrical supply	
			230V	400V					1/230V	3/400V

THREE PHASE

CBM-10/8 750 4PT C	4	750	3,6	2,1	3480	40	71	20	VFTM MONO 0,55	VFTM TRI 0,75
CBM-10/8 1500 4PT C	4	1500	8,5	4,9	6560	50	82	20,5	VFTM MONO 2,2	VFTM TRI 2,2
CBM-10/10 1500 4PT C	4	1500	10,1	5,8	7850	40	81	22	VFTM MONO 2,2	VFTM TRI 2,2
CBM-12/9 736 6PT C	6	736	4,7	2,7	5920	70	71	26,5	VFTM MONO 0,75	VFTM TRI 1,1
CBM-12/9 1100 6PT C	6	1100	7,3	4,2	6680	40	74	26,5	VFTM MONO 1,5	VFTM TRI 1,5
CBM-12/12 736 6PT C	6	736	4,8	2,8	5960	50	71	28,5	VFTM MONO 0,75	VFTM TRI 1,1
CBM-12/12 1100 6PT C	6	1100	7,4	4,3	7690	40	75	28,5	VFTM MONO 1,5	VFTM TRI 1,5
CBM-15/15 2200 6PT C K	6	2200	8,8	5,1	9100	40	72	43,2	VFTM MONO 2,2	VFTM TRI 2,2

* Sound pressure levels in dB(A), measured at 1,5 meters at the fan inlet side in free field.

DIMENSIONS (mm)

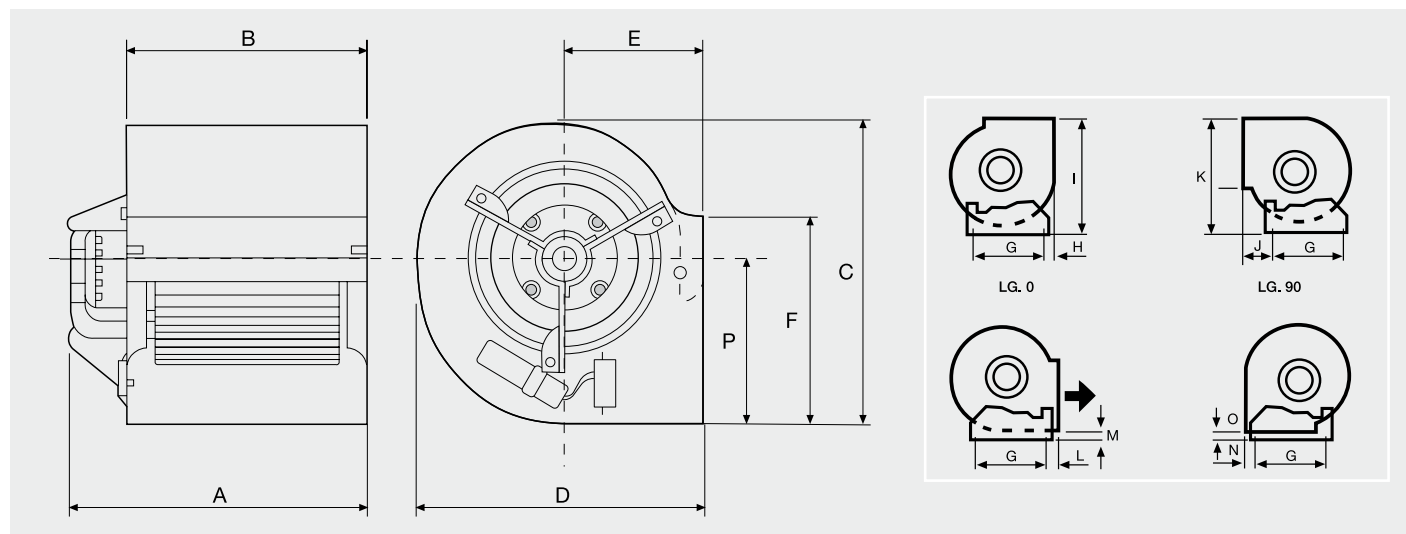

Model	A	B	C	D	E	F	G	H	I	J	K	L	M	N	O	P
CBM-7/7 72 6P C VR	270	233	327	308	145	207	225	47,6	314	57	333	28	16,4	8,6	6	187
CBM-9/7 373 4P C VR	306	234	390	381	184	260	296	34,5	382	69	395,5	68,5	39	34,5	6	221
CBM-9/9 373 4P C VR	348	300	390	381	184	260	296	34,5	382	69	395,5	68,5	39	34,5	6	221
CBM-9/9 550 4P C	348	300	390	381	184	260	296	34,5	382	69	395,5	68,5	39	34,5	6	221
CBM-10/8 245 6P C VR	328	267	443	423	200	288	339	39	427	67	451,5	67	40	39	8	249
CBM-10/8 373 4P C	357	267	443	423	200	288	339	39	427	67	451,5	67	40	39	8	249
CBM-10/10 245 6P C VR	377	333	443	423	200	288	339	39	427	67	451,5	67	40	39	8	249
CBM-10/10 550 4P C VR	388	333	443	423	200	288	339	39	427	67	451,5	67	40	39	8	249
CBM-12/9 550 6P C VR	419	311	521	490	229	341	407	40,5	496,5	69,5	528,5	69,5	38,5	41,5	4,5	293
CBM-12/9 736 6P C	421	311	521	490	229	341	407	40,5	496,5	69,5	528,5	69,5	38,5	41,5	4,5	293
CBM-12/12 736 6P C	459	396	521	490	229	341	407	40,5	496,5	69,5	528,5	69,5	38,5	41,5	4,5	293
CBM-10/8 736 4PT C		267	443	423	200	288	339	39	427	67	451,5	67	40	39	8	249
CBM-10/8 1500 4PT C	401	267	443	423	200	288	339	39	427	67	451,5	67	40	39	8	249
CBM-10/10 1500 4PT C	387	333	443	423	200	288	339	39	427	67	451,5	67	40	39	8	249
CBM-12/9 736 6PT C	419	311	521	490	229	341	407	40,5	496,5	69,5	528,5	69,5	38,5	41,5	4,5	293
CBM-12/9 1100 6PT C	416	311	521	490	229	341	407	40,5	496,5	69,5	528,5	69,5	38,5	41,5	4,5	293
CBM-12/12 736 6PT C	460	396	521	490	229	341	407	40,5	496,5	69,5	528,5	69,5	38,5	41,5	4,5	293
CBM-12/12 1100 6PT C	460	396	521	490	229	341	407	40,5	496,5	69,5	528,5	69,5	38,5	41,5	4,5	293

DIMENSIONS CBM-T-15/15 (mm)

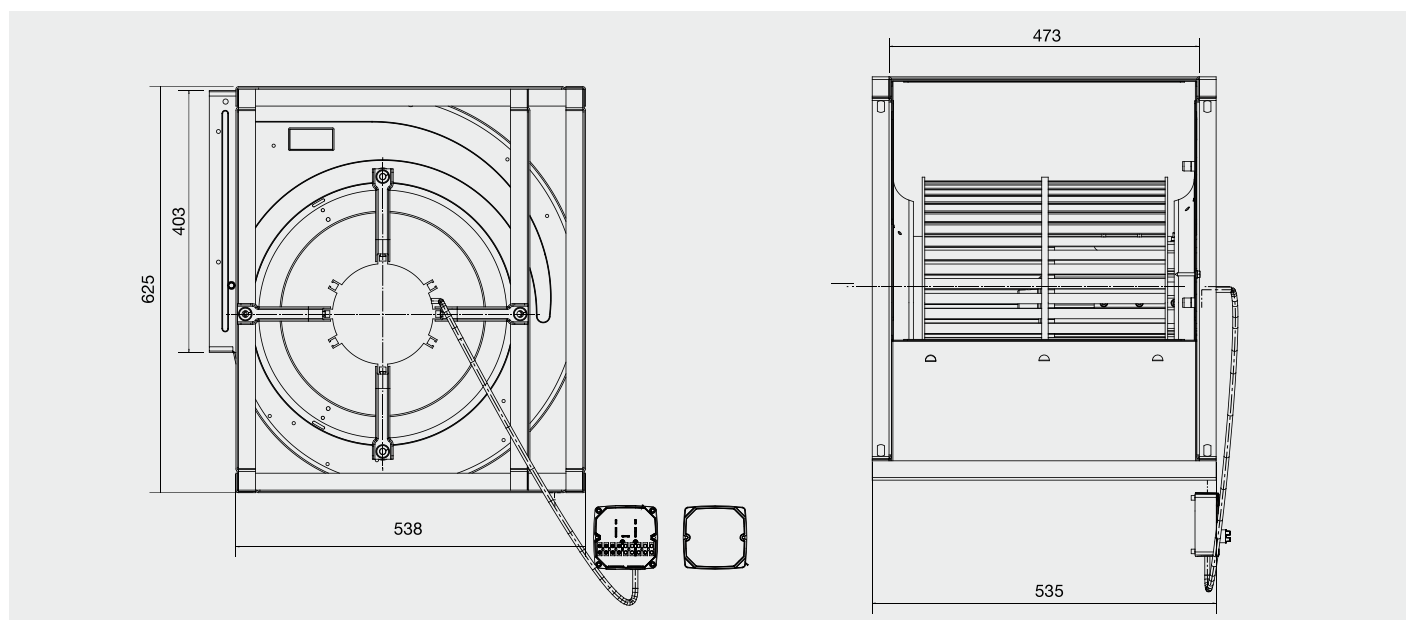

MOUNTING ACCESSORIES

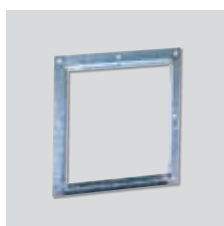

Outlet flange CBM



Mounting feet

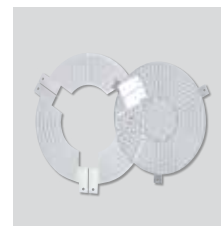

Inlet guard

Model	Outlet flange CBM	Mounting feet	Inlet guard
CBM-7/7	BRIDA DESCARGA CBM-7/7	PIE SOPORTE CBP/CBM 7/7	DEF-CBM-7
CBM-9/7	BRIDA DESCARGA CBM-9/7	PIE SOPORTE CBP/CBM 9/9	DEF-CBM-9
CBM-9/9	BRIDA DESCARGA CBM-9/9	PIE SOPORTE CBP/CBM 9/9	DEF-CBM-9
CBM-10/8	BRIDA DESCARGA CBM-10/8	PIE SOPORTE CBP/CBM 10/10	DEF-CBM-10
CBM-10/10	BRIDA DESCARGA CBM-10/10	PIE SOPORTE CBP/CBM 10/10	DEF-CBM-10
CBM-12/9	BRIDA DESCARGA CBM-12/9	PIE SOPORTE CBP/CBM 12/12	DEF-CBM-12
CBM-12/12	BRIDA DESCARGA CBM-12/12	PIE SOPORTE CBP/CBM 12/12	DEF-CBM-12
CBM-15/15	-	-	DEF-CBM-15

ACCESSORIES DIMENSIONS (mm)

Outlet flange CBM

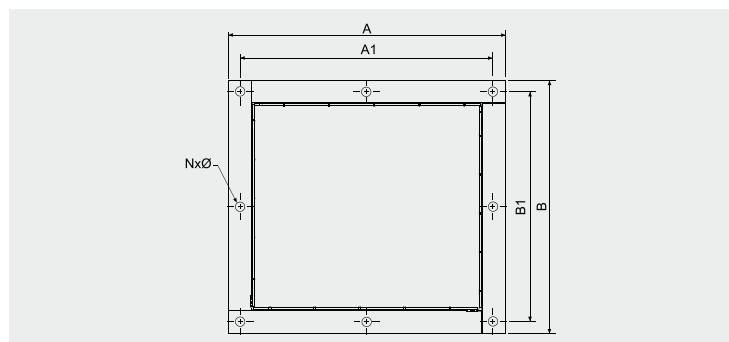

Model	A	A1	B	B1	NxØ (mm)
BRIDA DESCARGA CBM-7/7	289	264	265	240	8x9
BRIDA DESCARGA CBM-9/7	273	253	302	280	8x9
BRIDA DESCARGA CBM-9/9	360	328	315	285	8x10
BRIDA DESCARGA CBM-10/8	314	293	339	316	8x9
BRIDA DESCARGA CBM-10/10	380,5	359	339	316	8x9
BRIDA DESCARGA CBM-12/9	362	341	394,5	374	8x9
BRIDA DESCARGA CBM-12/12	447	426	394,5	374	8x9

Mounting feet

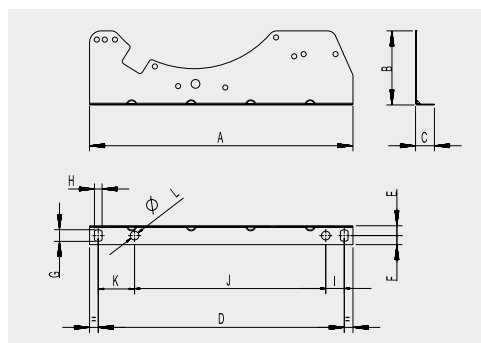

Model	A	B	C	D	E	F	G	H	I	J	K	L
7/	254	47	26	227	13,5	12,5	16	10,5	15	195	15	12
9/	325	102	26	297	13,5	12,5	16	10,5	-	-	35,7	10,5
10/	363	102	26	339	13,5	12,5	16	10,5	37,5	263,5	62	12
12/	434	144	26	407	13,5	12,5	16	10,5	48	333,5	25,5	12

PERFORMANCE CURVES

- p_{sf} : Static pressure in Pa.
- q_v : Airflow in m^3/h and m^3/s .
- SFP: Specific fan power in $W/m^3/s$.
- I: Absorbed current A.
- Measurement category: B.
- Efficiency category: total.
- Fan efficiency without VSD.
- Air flow data in accordance with ISO 5801.

- MC** Measurement category
- EC** Efficiency category
- VSD** VSD must be installed with the fan
- SR** Specific ratio
- η [%]** Overall efficiency
- N** Efficiency grade
- [kW]** Absorbed power
- [m^3/h]** Airflow
- [Pa]** Total pressure
- [RPM]** Speed

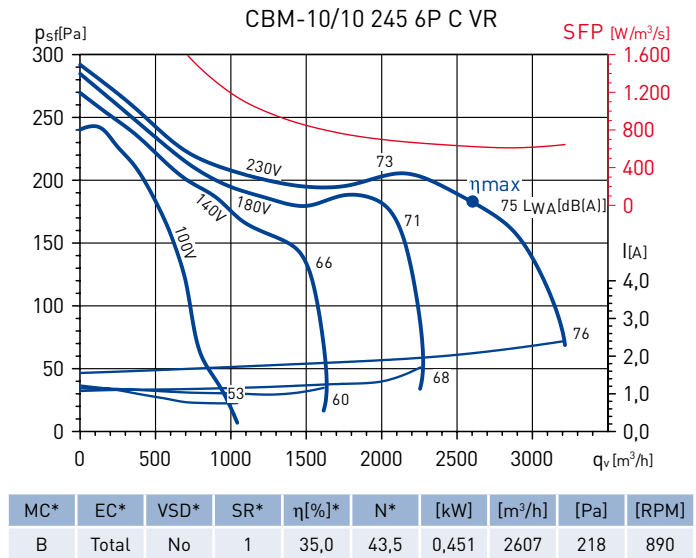

PERFORMANCE CURVES - SINGLE-PHASE MOTORS

- p_{sf} : Static pressure in Pa.
- q_v : Airflow in m^3/h and m^3/s .
- SFP: Specific fan power in $W/m^3/s$.
- I: Absorbed current A.
- Measurement category: B.
- Efficiency category: total.
- Fan efficiency without VSD.
- Air flow data in accordance with ISO 5801.

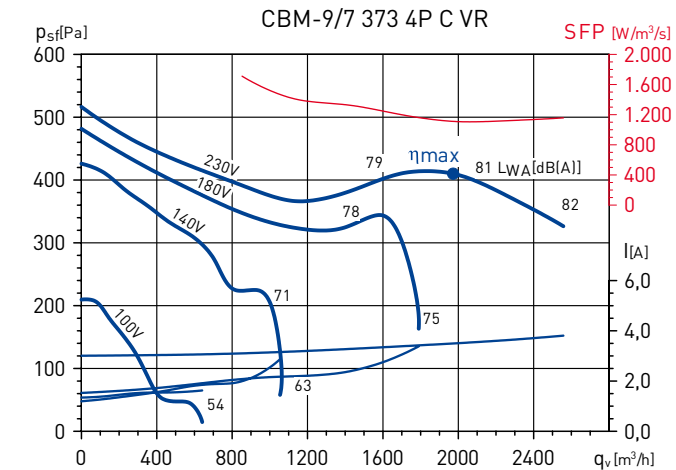
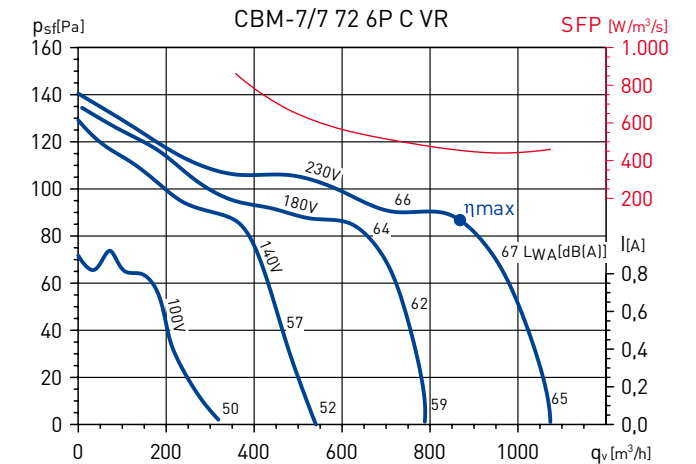

MC*	EC*	VSD*	SR*	η [%]*	N*	[kW]	[m^3/h]	[Pa]	[RPM]
B	Total	No	1	41,3	49,0	0,609	1976	458	1387

* See exampe curve.

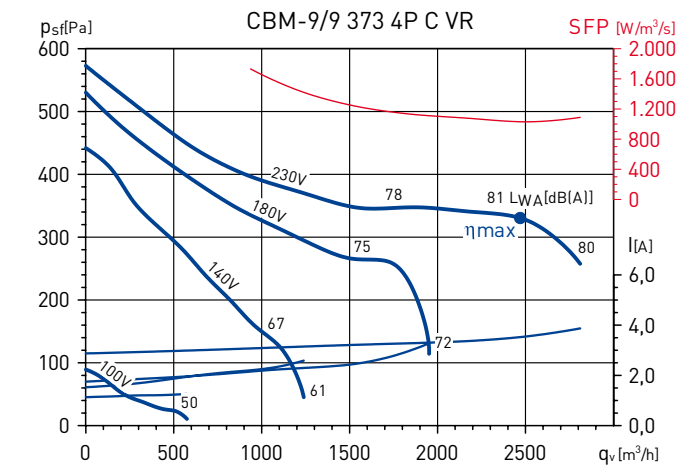

MC*	EC*	VSD*	SR*	η [%]*	N*	[kW]	[m^3/h]	[Pa]	[RPM]
B	Total	No	1	36,0	43,3	0,707	2461	376	1349

* See exampe curve.

PERFORMANCE CURVES - SINGLE-PHASE MOTORS

- p_{sf} : Static pressure in Pa.
- q_v : Airflow in m^3/h and m^3/s .
- SFP: Specific fan power in $W/m^3/s$.
- I: Absorbed current A.
- Measurement category: B.
- Efficiency category: total.
- Fan efficiency without VSD.
- Air flow data in accordance with ISO 5801.

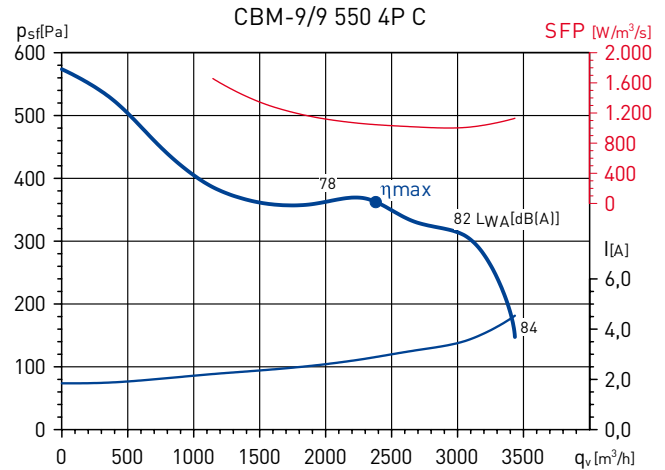

MC*	EC*	VSD*	SR*	η [%]*	N*	[kW]	[m^3/h]	[Pa]	[RPM]
B	Total	No	1	38,7	46,0	0,690	2374	404	1367

* See example curve.

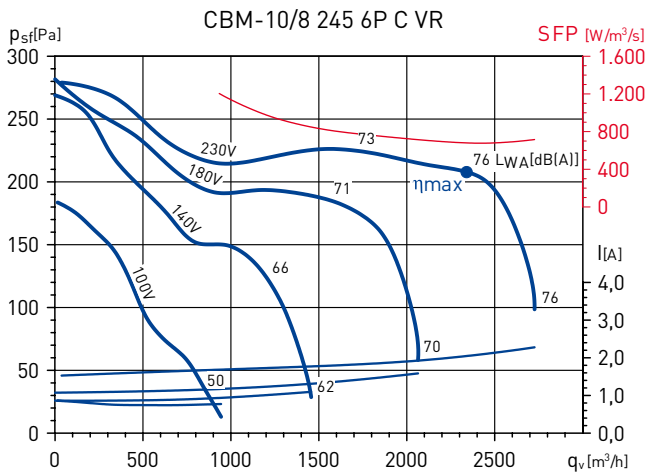

MC*	EC*	VSD*	SR*	η [%]*	N*	[kW]	[m^3/h]	[Pa]	[RPM]
B	Total	No	1	37,3	45,9	0,443	2349	255	879

* See example curve.

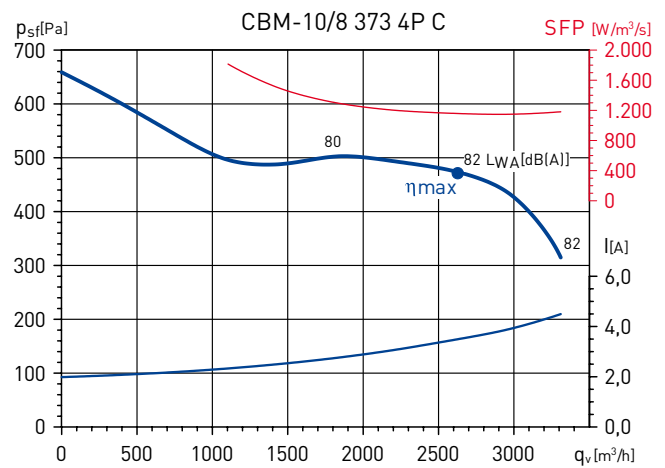

MC*	EC*	VSD*	SR*	η [%]*	N*	[kW]	[m^3/h]	[Pa]	[RPM]
B	Total	No	1	45,3	52,1	0,848	2635	524	1306

* See example curve.

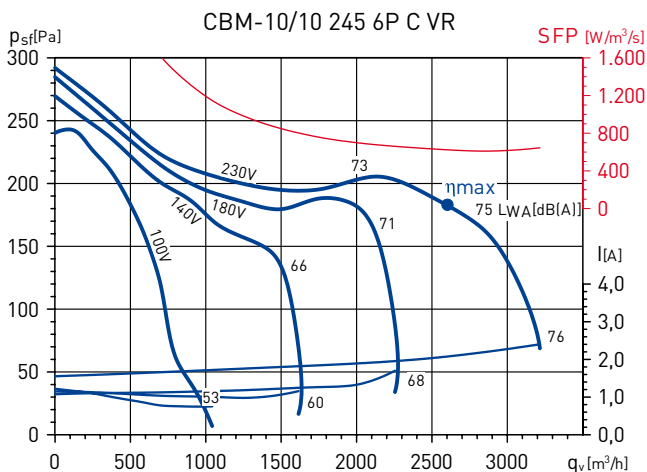

MC*	EC*	VSD*	SR*	η [%]*	N*	[kW]	[m^3/h]	[Pa]	[RPM]
B	Total	No	1	35,0	43,5	0,451	2607	218	890

* See example curve.

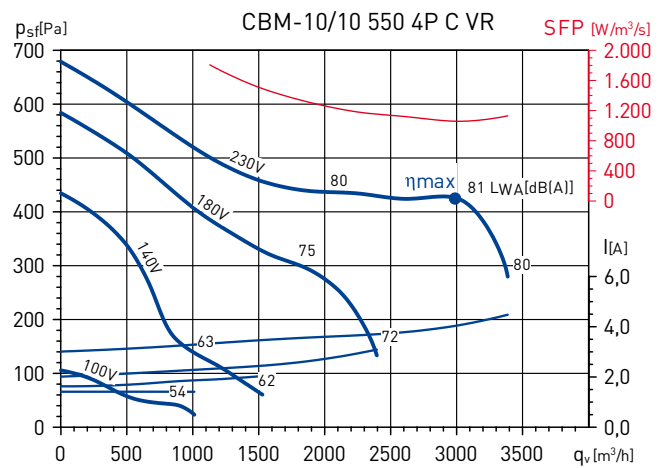

MC*	EC*	VSD*	SR*	η [%]*	N*	[kW]	[m^3/h]	[Pa]	[RPM]
B	Total	No	1	39,5	45,6	1,087	3194	484	1341

* See example curve.

PERFORMANCE CURVES - SINGLE-PHASE MOTORS

- p_{sf} : Static pressure in Pa.
- q_v : Airflow in m^3/h and m^3/s .
- SFP: Specific fan power in $W/m^3/s$.
- I: Absorbed current A.
- Measurement category: B.
- Efficiency category: total.
- Fan efficiency without VSD.
- Air flow data in accordance with ISO 5801.

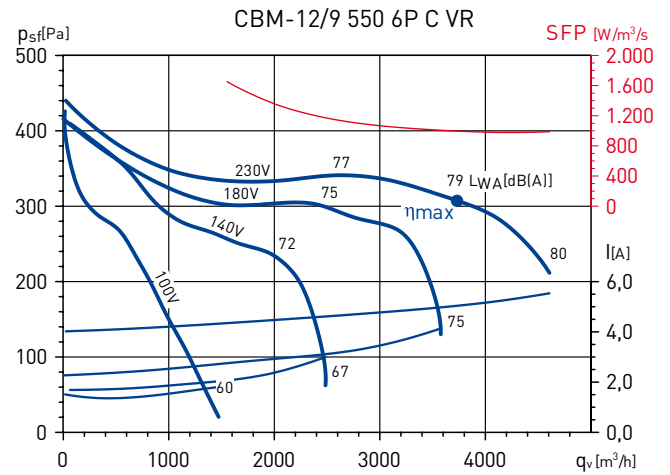

MC*	EC*	VSD*	SR*	η [%]*	N*	[kW]	[m³/h]	[Pa]	[RPM]
B	Total	No	1	36,8	43,0	1,033	3728	367	887

* See exemple curve.

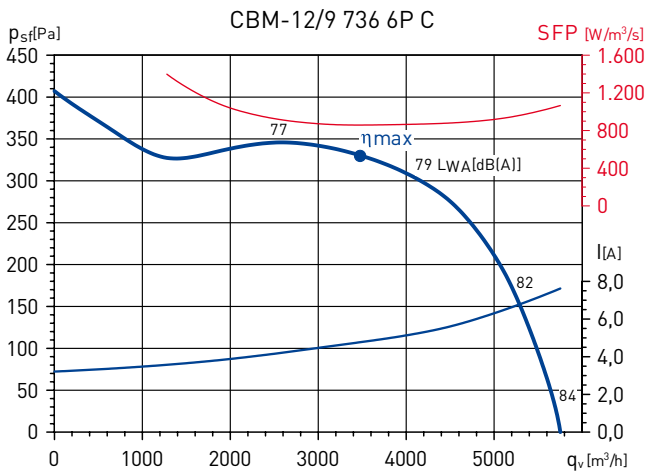

MC*	EC*	VSD*	SR*	η [%]*	N*	[kW]	[m³/h]	[Pa]	[RPM]
B	Total	No	1	44,5	51,3	0,830	3485	382	941

* See exemple curve.

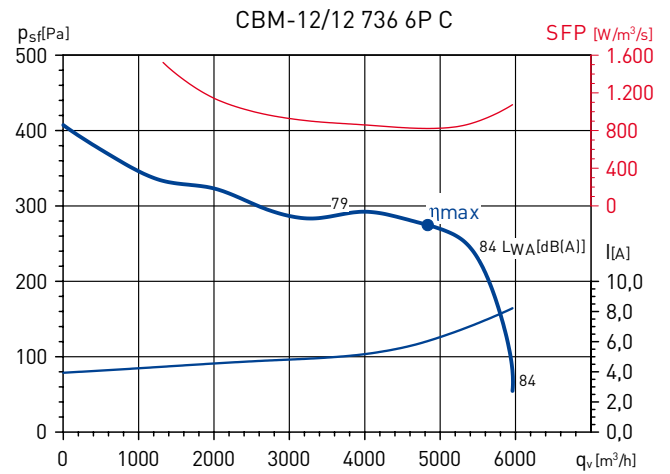

MC*	EC*	VSD*	SR*	η [%]*	N*	[kW]	[m³/h]	[Pa]	[RPM]
B	Total	No	1	40,6	46,6	1,112	4895	340	904

* See exemple curve.

PERFORMANCE CURVES - THREE-PHASE MOTORS

- p_{sf} : Static pressure in Pa.
- q_v : Airflow in m^3/h and m^3/s .
- SFP: Specific fan power in $W/m^3/s$.
- I: Absorbed current A.
- Measurement category: B.
- Efficiency category: total.
- Fan efficiency without VSD.
- Air flow data in accordance with ISO 5801.

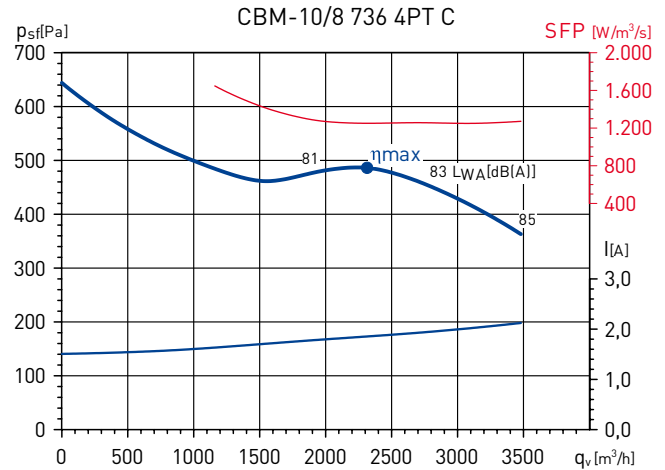

MC*	EC*	VSD*	SR*	η [%]*	N*	[kW]	[m^3/h]	[Pa]	[RPM]
B	Total	No	1	42,2	49,1	0,803	2310	527	1351

* See example curve.

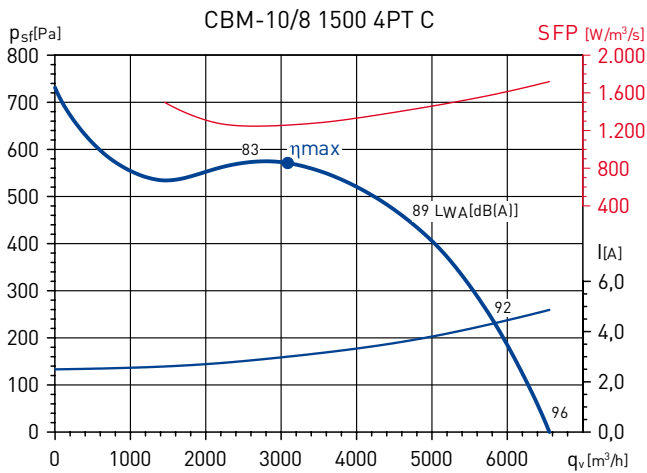

MC*	EC*	VSD*	SR*	η [%]*	N*	[kW]	[m^3/h]	[Pa]	[RPM]
B	Total	No	1	51,1	57,2	1,075	3081	642	1459

* See example curve.

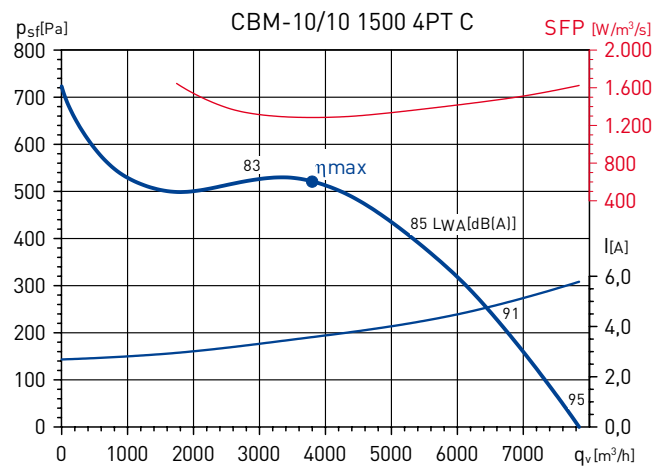

MC*	EC*	VSD*	SR*	η [%]*	N*	[kW]	[m^3/h]	[Pa]	[RPM]
B	Total	No	1	45,7	51,2	1,355	3801	587	1462

* See example curve.

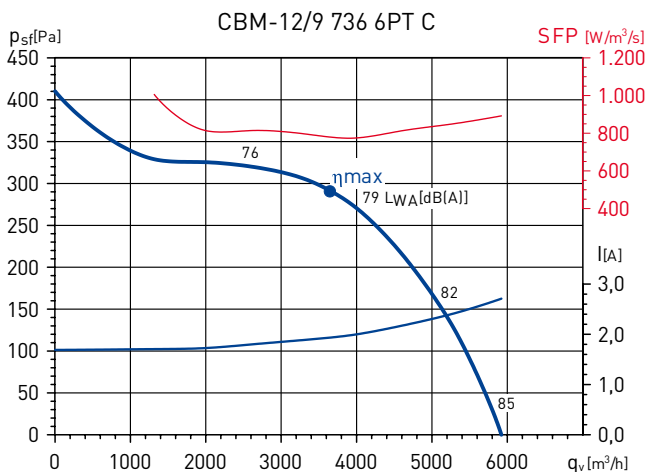

MC*	EC*	VSD*	SR*	η [%]*	N*	[kW]	[m^3/h]	[Pa]	[RPM]
B	Total	No	1	44,9	51,9	0,784	3657	347	899

* See example curve.

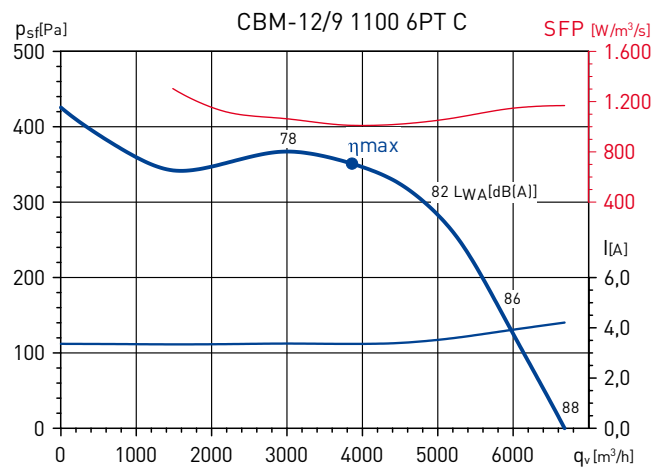

MC*	EC*	VSD*	SR*	η [%]*	N*	[kW]	[m^3/h]	[Pa]	[RPM]
B	Total	No	1	40,7	46,8	1,088	3867	412	941

* See example curve.

PERFORMANCE CURVES - THREE-PHASE MOTORS

- p_{sf} : Static pressure in Pa.
- q_v : Airflow in m^3/h and m^3/s .
- SFP: Specific fan power in $W/m^3/s$.
- I: Absorbed current A.
- Measurement category: B.
- Efficiency category: total.
- Fan efficiency without VSD.
- Air flow data in accordance with ISO 5801.

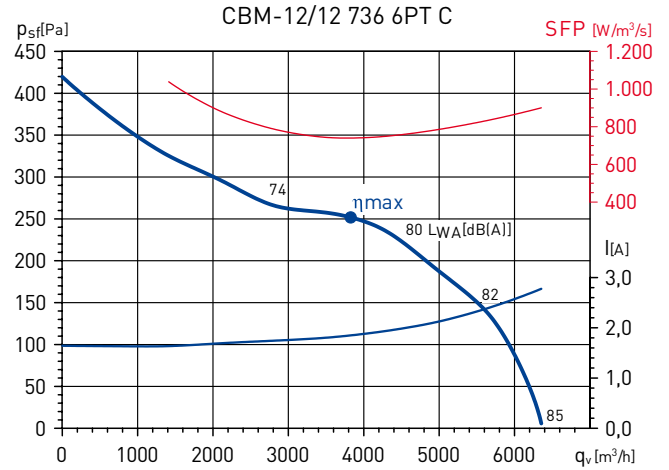

MC*	EC*	VSD*	SR*	η [%]*	N*	[kW]	[m³/h]	[Pa]	[RPM]
B	Total	No	1	39,7	46,7	0,791	3850	293	885

* See exame curve.

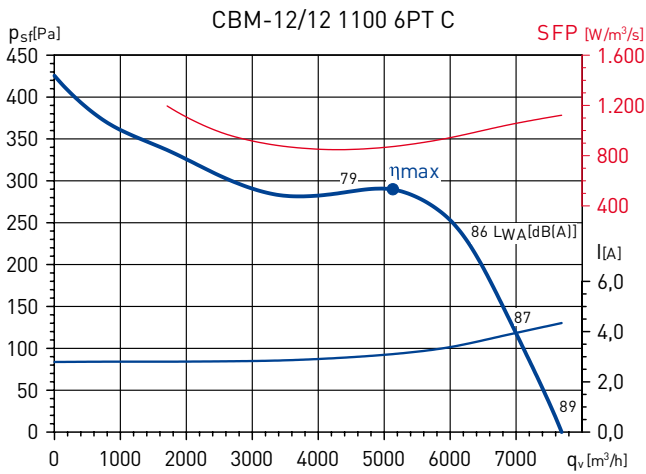

MC*	EC*	VSD*	SR*	η [%]*	N*	[kW]	[m³/h]	[Pa]	[RPM]
B	Total	No	1	41,1	46,8	1,243	5130	359	938

* See exame curve.

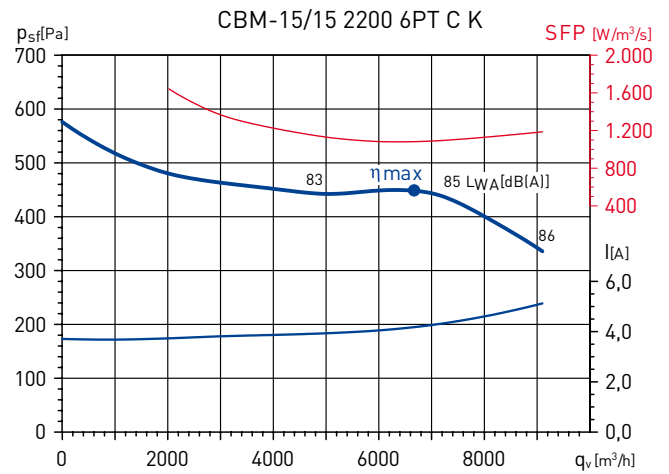

MC*	EC*	VSD*	SR*	η [%]*	N*	[kW]	[m³/h]	[Pa]	[RPM]
B	Total	No	1	46,7	51,1	2,009	6688	506	913

* See exame curve.